

# Air Operated Drill Type: **AK** SERIES

## AK-01

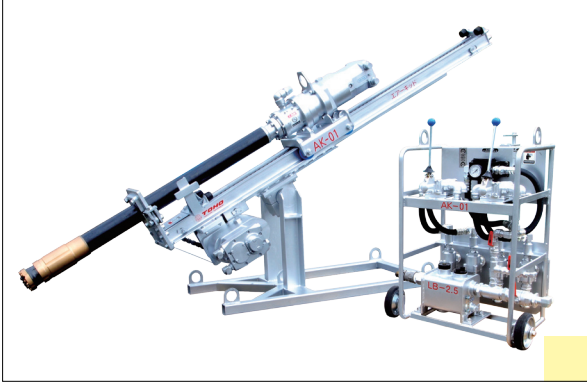

### ■ Air drilling

Able to reduce running cost and time using air driving method

### ■ Drill head with strong air motor

Drill head with reduction gear exerts great drilling torque

### ■ Double tube drilling

Makes it easy to drill into unstable stratum

MODEL	AK-01
Drilling angle	free
Down the hole drill (mm)	φ65
Down the hole drill with outer casing (mm)	Drilling diameter φ106 (Inside diameter φ67) Drill rod φ50, Outer casing φ89.1 (φ106 Bit dia.)
Spindle speeds (rpm)	0~30
Torque(Max) (kN·m)	1.23 {125 kgf·m}
Drill frame	Air motor + Chain drive
Thrust force (kN)	7.84 {800 kgf} (Max)
Balance force (kN)	7.84 {800 kgf} (Max)
Feed length (mm)	1400
Air consumption	10~15 m <sup>3</sup> /min x 1~1.5MPa
Dimensions (L x W x H) (mm)	2190 x 660 x 980
Mass (kg)	Drive unit: 230
Disassembly (kg)	Drill head: 65 Drill frame:125 Base: 40
Operation stand (kg)	65

Feed length is 3500mm

### Double Tube Type System 【Ring Bit (106 x 89.1) Components】

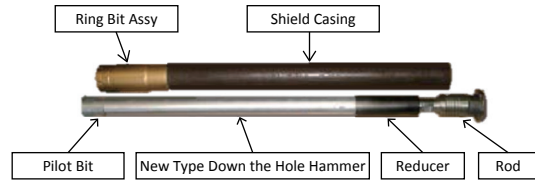

### Setting



### 【Air Kid (AK-01) Layout】

Machine and Tubular Scaffolding

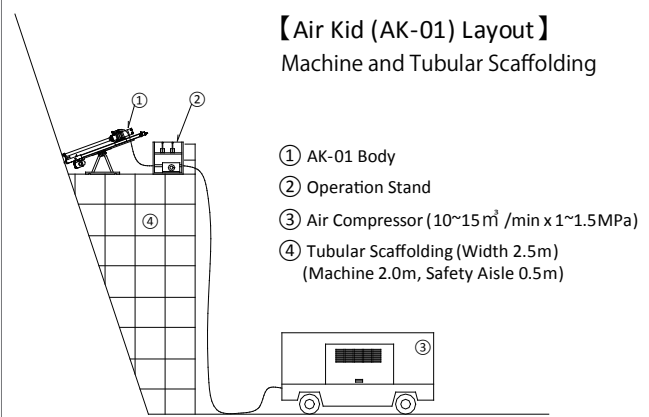

### General View

