

# Mud Screen: **TM** SERIES

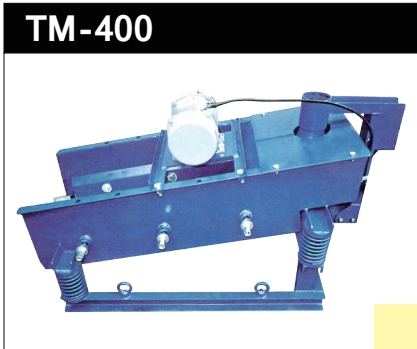

MODEL	TM-400
Type	Single screen type
Disposable capacity (L/min)	500
Inlet diameter (mm)	75
Screen area (m <sup>2</sup> )	0.3
Power	0.25 kW/4P vibration motor
Dimensions (L x W x H) (mm)	1250 x 600 x 960
Mass (kg)	144

Setting with electric motor and control box

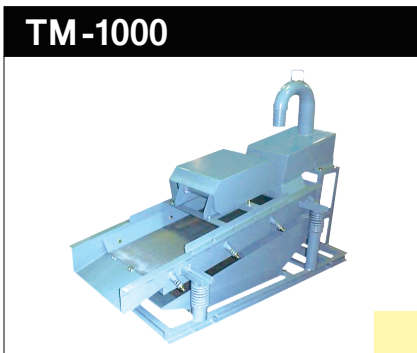

MODEL	TM-1000
Type	Single screen type
Disposable capacity (L/min)	1000
Inlet diameter (mm)	100
Amplitude of vibration (mm)	3
Screen area (m <sup>2</sup> )	0.8
Power	0.75 kW/4P
Dimensions (L x W x H) (mm)	2175 x 980 x 1455
Mass (kg)	310

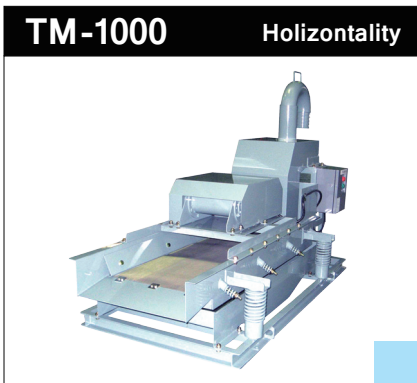

MODEL	TM-1000 (Horizontality)
Type	Single screen type
Disposable capacity (L/min)	1000
Inlet diameter (mm)	100
Amplitude of vibration (mm)	3
Screen area (m <sup>2</sup> )	0.8
Power	0.75 kW/4P
Dimensions (L x W x H) (mm)	2182 x 980 x 1455
Mass (kg)	310

Setting with electric motor and control box



MODEL	TM-1000W
Type	Double screen type
Disposable capacity (L/min)	1000
Inlet diameter (mm)	100
Amplitude of vibration (mm)	upper: 3 lower: 1
Screen area (m <sup>2</sup> )	1.6
Power	1.5 kW/4P
Dimensions (L x W x H) (mm)	2170 x 970 x 1690
Mass (kg)	450

Setting with electric motor and control box

## TMP Series

- Suitable at the site used large amount of circulating mud water
- Small amount of screenings and waste mud
  - ↳ Less disposal cost